



TABLE INSTALLATION, OPERATION AND MAINTENANCE

Safety

Although the procedures covered in this manual have proven safe in use, Knight Industries assumes no responsibility for personal injury or damage to the equipment resulting from their application. It is not possible to cover all safety conditions in this manual. Therefore, always be alert and work safely. Only qualified machine operators and maintenance personnel should perform the procedures covered in this manual.

- Do not operate table without proper training and authorization.
- Read, understand and follow all notes, cautions, warnings and instructions contained in this manual and the hazard warnings on the table.
- Keep area around table free of oil, objects and debris that could cause personnel to slip or stumble while operating table.
- All personnel operating this device should wear safety glasses and steel toed shoes.
- Perform daily inspections at every shift change.
- Do not lubricate air supply. Lubricating air supply can damage parts and will void the warranty.
- Do not locate the controls in front of a tilt table. Locate controls inline with tilt angle on table.
- Never go under the table unless unit is properly locked out and all maintenance safety devices are engaged.
- If load is mobile, secure load in a fixed position before lifting.
- Do not operate table with a load unless secured to the floor.
- All loads should be centered on the table top before lifting.
- Prior to operating the table, ensure that all personnel on or near the table are aware of its imminent operation and that no person will be in harms way during the use of the unit.
- Ensure that objects are clear of the area beneath the table and immediately surrounding perimeter of the table while its in use.
- The table shall not be modified or altered without written permission from the manufacturer.

Warranty

Product Warranty

Knight Industries and Associates warrants to the original use purchaser of Knight Industries manufactured tables that Knight Industries will repair or replace, free of charges, such product, which under normal use and service, proves to be defective in material or workmanship, as determined by Knight Industries inspection, provided the claimed defective product, or part thereof, is promptly returned to Knight Industries factory with transportation charges prepaid. See purchase agreement for term of warranty.

This Warranty may be altered only in writing by Knight Industries and Associates, Auburn Hills, Michigan

Warranty Information

This manual is not intended to be or to create any other Warranty, express or implied, including any implied Warranty of merchantability or fitness for a particular purpose, all of which are hereby expressly excluded. As set forth more specifically in the product warranty, Knight Industries obligation under that warranty is limited to the repair or replacement of defective components, which shall be the buyer's sole remedy, and Knight Industries shall not be liable for any loss, injury, or damage to persons or property, nor for any direct, indirect or consequential damage of any kind resulting from the table.

Installation

NOTE

Before installing, check all codes and ordinances which may apply.

Read all instructions carefully. Read and understand all warnings.

1. Remove table from skid and/or remove shipping blocks.
2. Set the table at desired location, the table should be installed in a level position. Locate controls a minimum of 3' [1 m] away from the table.

NOTE

Do not locate the controls in front of a tilt table. Locate controls inline with tilt angle on table

Continued from previous page

3. Connect air lines, match the label on the air line to the label on the fitting on table base. (i.e. 1 to 1 and 2 to 2).

NOTE

Main air supply must be clean, dry and not lubricated. Operating pressure is between 60 and 100 psi. A filtration of 40 microns or better is required. Filter, regulator and dryer to be supplied by others.

4. Connect main air supply to air "IN" connection on the controls.
5. Before securing the table to the floor turn on the main air supply. Check air lines and connections for leaks.
6. Before securing the table perform the following without dunnage (See Operation):
 - Lift the table using the controls.
 - Inspect the table and maintenance devices.
 - Return table to down position. The table should move smoothly and quietly.
 - Inspect the table, hoses and controls for damage or pinch points.
7. Raise table and secure maintenance bar (See Maintenance Bar).
8. Secure the table to the floor (See Stud Anchor recommendations). Anchoring points are located at the base of the table. All anchoring points are to be used.

Stud Anchor Recommendations

Before operating the Knight Industries table, it is imperative that the equipment is securely anchored in place. The recommended anchoring method is the use of expandable carbon steel stud anchors installed in a structurally sound concrete floor at each equipment attachment point. The anchoring studs shall be rated to the following specifications:

- Rated to government G.S.A. spec: FF-S-325 Group VIII-Type1
- 5/8-11 stud thread (2" minimum thread length)
- 2 3/8" minimum embedment in concrete
- 4 1/2" [11.4 cm] minimum overall length
- Pullout rating 7,700 lbs [3493 kg]
- Shear rating 11,200 lbs [5080 kg]

Example studs which meet these specifications:

- Powers brand power stud CAT # 7432
- RED HEAD brand PT # JS-58H

Operation

NOTE

Before operating, read the entire manual and understand all instructions and warnings.

If it is necessary to stop the unit before it reaches the closed position, the control must be manually returned to the "NEUTRAL" position.

On rotating tables engage brake before loading.

Load and unload the table in the complete down position only.

If the table does not operate, makes unusual noises or seems unsafe, cease operation immediately and notify maintenance personnel.

On rotating tables be sure the brake is on when lifting or lowering the table.

Raise:

- Ensure the load is centered on table.
- Raise the table by moving the control valve to the "Lift Up" position.
- Return control valve to neutral position when at desired height.

Lower:

- Lower the table by moving the control valve to the "Lift Down" position.
- Return control valve to neutral position when at desired height.

Rotate:

- Release the brake, Manually turn table to desired position. Turn the brake on.

Tilt:

- Increase the tilt angle by moving the control valve to the "Tilt Up" position.
- Return control valve to neutral position when at desired tilt.
- Lower the tilt by moving the control valve to the "Tilt Down" position.
- Return control valve to neutral position when at desired height.

Maintenance

Maintenance Bar

WARNING

Remove load from equipment. Never attempt to service any table with weight on platform.

Remove all debris from around and inside table.

Never attempt to raise table with forks from lift truck.

1. Raise table using control valve.
2. Lower maintenance bar. (See photo on back page) so that bar rests on bottom of the lift table pan.
3. Lower table using control valve until bar comes into contact with table pan wall.

CAUTION

Whenever possible leave system pressurized. (during installation and removal etc).

4. When maintenance is complete, raise table using control valve and return maintenance bar to its support rest.

Incapacitated Table

WARNING

Remove load from equipment. Never attempt to service any table with weight on platform.

Remove all debris from around and inside table.

Never attempt to raise table with forks from lift truck.

1. Disconnect air supply and remove control valve. This will allow air to enter system and avoid creating a vacuum.
2. Remove scissors pivot pins from pan and remove top assembly. With top pan removed and scissor base exposed perform services as needed.

CAUTION

Improper maintenance procedures can kill!! Read and follow all instructions in this manual. For maintenance or service that is not covered in this manual, call Knight Industries service department for recommendations and instructions. Phone: (248) 377-4950 ext. 162.

Inspection

Timely and effective maintenance will ensure that your Knight system performs at peak efficiency. Under most typical operating conditions, the system will require only minimal maintenance. However, there are a few critical areas in which regular maintenance attention is critical. These areas include:

- (DAILY) Visually inspect air lines for damage, kinks, or wear.
- (DAILY) Inspect for loose or missing parts.
- (DAILY) Check all controls for ease of operation.
- (WEEKLY) Check for missing or loose screws.
- (WEEKLY) Ensure all hose connections are intact and there are no leaks.
- (WEEKLY) Check for any damage that may hamper any free movement.

General Spare Parts List

Part Number	Part Description
TBA1102A	Knight Valve Hand Control
TBA1103A	Knight Valve Foot Control
T-358-8044	Knight Air Bag
BSS100T	Bellows Skirting For Tilt Table
BSS100L	Bellows Skirting For Lift Table
BSS100LT	Bellows Skirting For Lift And Tilt Table
MSD-100	Motion Stabilizer
TVA-100P	Pedestal Control Assembly-Tilt
TVA100F	Foot Control Assembly-Tilt
T-WA3850	Knight Wheel Axle Assemblies
LTVA-100P	Pedestal Control Assembly-Lift And Tilt
LTVA-100F	Foot Control Assembly-Lift And Tilt
T-2001	Air Brake Control Foot
T-2003	Air Brake Control Hand
T-20-0414R	Roteck Bearing Assembly
T-C721X	Fabco Cylinder For Air Brake
T-721BP-2	Nylon Pad For Brake Assembly
LRVA-100P	Pedestal Control Assembly-Lift And Rotate
LRVA-100F	Foot Control Assembly-Lift And Rotate
LVA100P	Pedestal Control Assembly-Lift
LVA100F	Foot Control Assembly-Lift
T-CA2850	Caster Bearing And Shaft Assembly

Lift Table With Optional Equipment

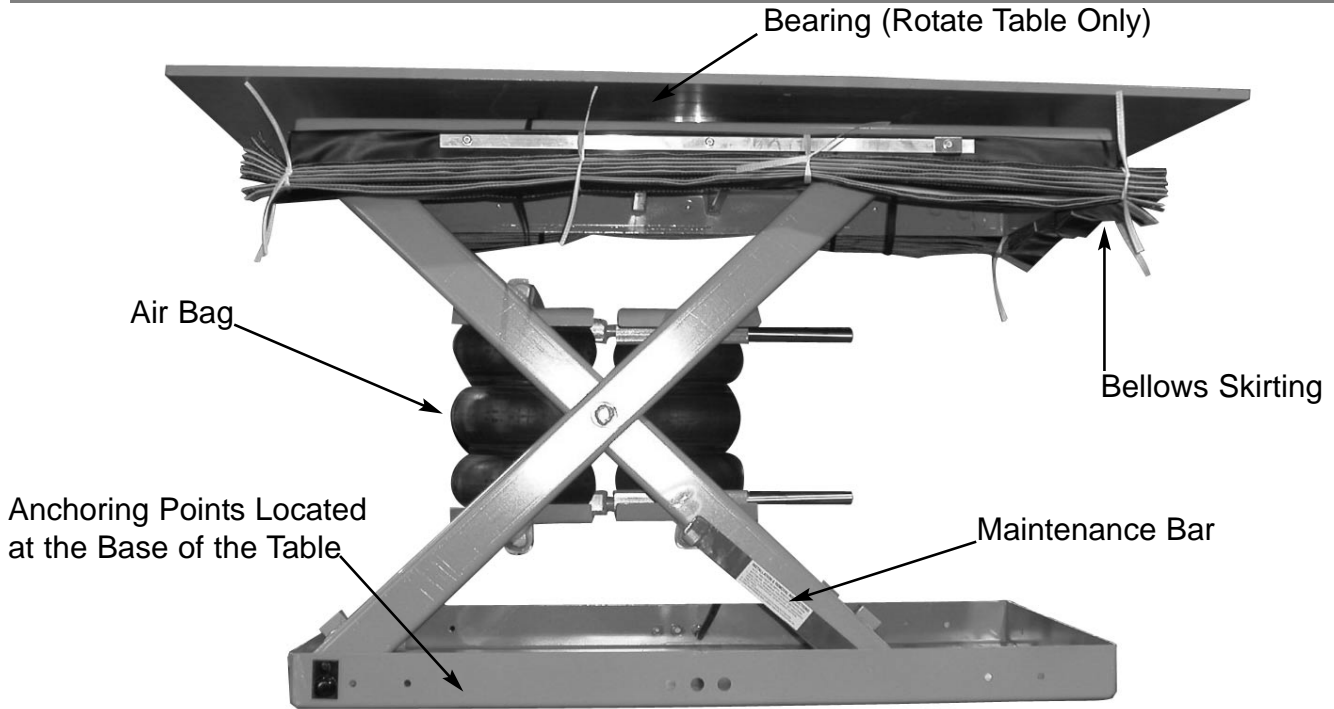

Tilt Maintenance Bar (Rest Position)



Lift Maintenance Bar (Engaged Position)

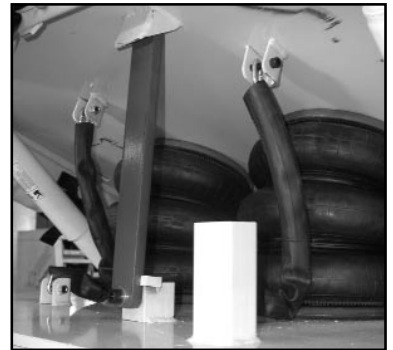

Tilt Maintenance Bar (Engaged Position)

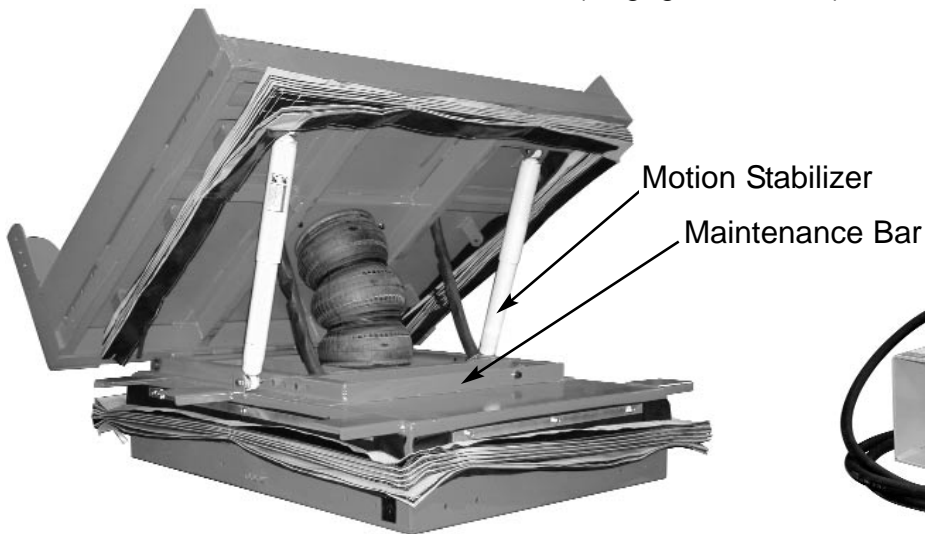

Foot Control

Hand Control