



Servo Systems



Rail Systems



Balancers



Ergo Assists



Controls



Tables , Carts & Shuttles

▶ Product *Catalog*

KNIGHT

PROVEN INNOVATORS

of Material Handling Systems



▶ **IDEA**

Knight has the ability to transform a concept...

DESIGN ◀

by incorporating State-of-the-Art CAD Systems...

▶ **BUILD**

and using the latest machining, fabrication, and assembly technologies...

REALITY ◀

to solve your ergonomic material handling needs.

▶ **QUALITY**

Knight has achieved the highest Quality Assurance Certifications
ISO 9001:2000, ISO14001:2004 and Ford Q1.

We are committed to Total Customer Satisfaction through
QUALITY, RELIABILITY AND EMPLOYEE INVOLVEMENT

Knight Industries warrants its products and parts meet all applicable specifications and performance requirements for one year from the date of invoice. Individual items may have their own warranties. Exclusions include, (but are not limited to), inadequate training provided by the customer regarding operation and/or maintenance of the tool, misuse, sabotage, maladjustment, or alteration not approved by Knight Industries.

Buyer must submit a claim through the Return Goods Authorization process by contacting the Customer Service Department. All rework is to be done at Knight Industries unless otherwise agreed to arrangements are made. Buyer is responsible for all internal removal and reinstallation costs, as well as freight charges to and from Knight.

After substantiation of claim, Seller is only responsible to repair or replace its product, and/or meet performance requirements per the original stated contract. Seller is not liable for incidental or consequential damages.

<u>Servo Systems</u>	
Servo Hoist	1
Twin Chain	1
Articulating Extension Arm	1
Extension Arm	1
Vertical Arm	2
Vertical Articulating Arm	2
Servo Hoist and Tractor	2
Servo Rack and Pinion Tractor	2
Servo Hoist Accessories	1-2
<u>Rail</u>	
Aluminum Rail	3
Steel Rail	3
Tool Rail	3
Engineered Rail	4
Jib Cranes	4
Rail Accessories	4
<u>Balancers</u>	
Single Cable	7
Single Chain	7
Dual Drum	7
Reeved	7
Tandem	7
Tandem Reeved	7
Pneumatic Controls	8
Balancer Accessories	8
<u>Ergo Assists</u>	
Articulating Arms	9
Extension Arms	9
Path Guided Arms	9
Carriage Arms	9
Lean Tools	9
Vertical Mast Arms	10
Torque Packs	10
Side Mounted Arms	10
Tool Bench Mounted Arms	10
Tool Holders	10
End of Arm Tooling	11
<u>Controls</u>	
Pneumatic Control Handles	13
Electric Control Handles	13
Lever Options	13
<u>Tables, Shuttles and Carts</u>	
Lift Tables	14
Lift and Rotate Tables	14
Low Profile Lift Table	14
Low Profile Lift & Rotate Table	14
Lift & Tilt Tables	14
Double Scissor Lift Tables	14
Turntables	14
Push / Tugger Carts	14
Tilt Tables	15
Slide-Tilt Tables	15
Corner Tilt Tables	15
Cart Lift	15
Hydraulic Cart Lift	15
Operator Platform Lift	15
Smart Carts	15
Small Footprint Zero Loader	16
Zero Loader	16
Shuttle Systems	16
Powered Accumulators	16
Non-Powered Accumulators	16
Small Footprint Over/Under System	16
Table Accessories	16

Servo Systems

Knight Servo Systems are Intelligent Assist Devices (IAD) that provide controlled transfer of workloads. The user-friendly equipment enhances repeatable precision and speed for any application. Standard or custom options allow for various programmed product functions.

Servo Accessories



Inline Control Handle

Programmable handle includes a run-stop button, programmable port, and I/O configuration port.

Model# EBA1000 Shown



Dual Speed Handle (DSH)

Equipped with the same features of a Standard Inline Handle. Available in single or two speed configuration. This unit may be mounted on a separate cable.

Model# EBA1010 Shown



LCD Display Handle

Microprocessor based control handle which displays information on an LCD screen. Operator movement/force can be more accurately detected, resulting in a smoother, more responsive reaction.

Model# DBA1000 Shown



Dual Speed Handle without pushbutton

Non-programmable handle is available in a single or two speed configuration. This unit may be mounted on a separate cable.

Model# EBA9100 Shown



Load Cell

Used in conjunction with the Dual Speed Handle when an Inline handle is not a practical solution for the application.

Model# EBA1007 Shown

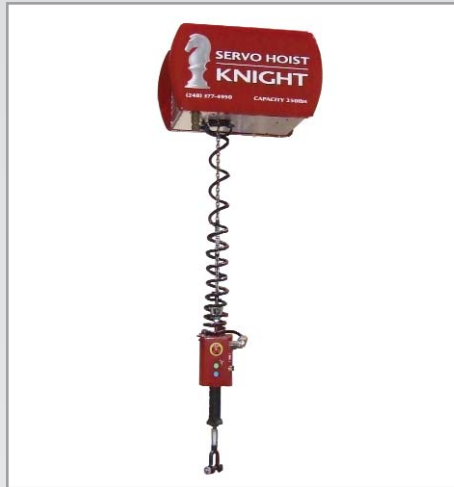

Servo Hoist

Enables the operator to precisely locate and/or float a load in the "Z" direction using programmable limits. Standard hoist has a lifting capacity up to 1000 lbs.[454kg] (Reeved unit) and travels up to 200' fpm[70mpm].

Model# KSHAEA250-2301 Shown



Servo Hoist Twin Chain

Incorporates the benefits of a Servo System into a twin chain process. The twin chains help control unwieldy or long parts. Standard hoist has a lifting capacity up to 1000 lbs.[454kg] (Reeved unit) and travels up to 200' fpm[70mpm].

Model# KSHTC250-2301 Shown



Servo Hoist Articulating Extension Arm

Servo Hoist mounted on an articulating boom allows for non-linear reach within a work cell. Standard hoist has a lifting capacity up to 250 lbs.[113kg] and travels up to 200' fpm[70mpm].

*** 500, 700 and 1000lb arms are application dependent and are considered a special order.*

Model# KSH250-2301 Shown



Servo Hoist Extension Arm "Overhead Mounted"

Incorporates a Servo Hoist within a boom. Enables the operator to reach outside the area directly below the rail. Standard hoist has a lifting capacity up to 250 lbs.[113kg] and travels up to 200' fpm[70mpm].

*** 500, 700 and 1000lb arms are application dependent and are considered a special order.*

Model# KSHAEA250-2301 Shown



Servo Hoist Vertical Articulating Arm "Floor Mounted"

Servo Hoist mounted on a vertical aluminum mast. The boom enables the operator to reach underneath areas in a confined work cell. Standard hoist has a lifting capacity up to 250 lbs.[113kg] and travels up to 200' fpm[70mpm].

*** 500, 700 and 1000lb arms are application dependent and are considered a special order.*

Model# KSHVAA250-2301 Shown



Servo Hoist Vertical Arm "Overhead Mounted"

Servo Hoist mounted on a vertical aluminum mast creates a steady state condition. Eliminates the yarding of a cable or chain. Standard hoist has a lifting capacity up to 1000 lbs.[454kg] and travels up to 200' fpm[70mpm].

Model# KSHVA250-2301 Shown



Servo Hoist and Tractor

Combines "X", "Y", and "Z" movements in one handle. Standard hoist has a lifting capacity up to 1000 lbs.[1814kg] and travels up to 184' fpm[56mpm].

Model# KSHXZ Shown



Servo Rack and Pinion Tractor

Accurately locates a load in the "X" and/or "Y" direction. Standard tractor moves a load up to 4000 lbs.[1814kg] and travels up to 184' fpm [56mpm].

Model# KST4000 Shown

Servo Accessories

2" Hook

Hook has an open bend to keep load inline with the chain.

Model# EBA1001 Shown



Shackle

Secures fixtures or loads inline with the chain.

Model# EBA1002 Shown



Quick Connect

Allows for fast and easy changes of standard or customized end effectors

Model# EBA1008 Shown



Coil Cable

Cable surrounds Servo Hoist chain providing a clean, compact package.

Model# EBA1011-6 Shown



Pendant Cable

Configuration used with the DSH. Provides flexibility to remotely mount handle.

Model# EBA1009-3 Shown



Load Trolley

Attaches Servo Hoist to Knight 7500 & 4100 Series Rail.

Model# EBA1030 Shown



Rail Systems

Knight Rail Systems are designed to provide a safe, efficient solution to your ergonomic challenges. A wide range of options are available to meet specific engineering or application requirements. All suspension systems include an enclosed trolley track that resists dirt build-up for a smoother, quieter operation. A Knight Representative can assist you in selecting and developing alternatives when designing your rail system.

Overhead Rail Suspension System

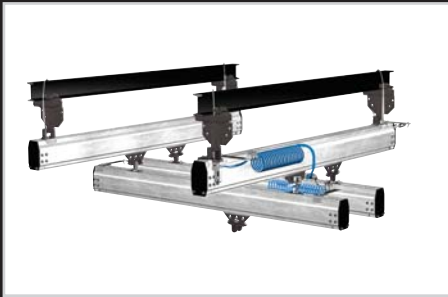

Floor Mounted Rail Suspension System



Overhead and Floor Mounted Rail Suspension Systems are available in dual or single bridge configurations.



Aluminum Rails

Knight Aluminum Enclosed Track Rail is extruded from high strength aluminum alloy with a load capacity up to 3000 lbs. [1360kg]. The lightweight rail is offered in three sizes: RAD7500 8" [203mm], RAD4100 4" [101mm], and TR2000 2" [51mm]. Lengths range up to 25' [7.62m] without the need for a splice. Rail is also available in curved sections.



Steel Rails

Knight Steel Enclosed Track Rail is ideal for offset and side loading applications with load capacities up to 1000 lbs. [454kg]. The rail is offered in three sizes: RSD5700 7" [178mm], RSD5500 6" [152mm], and RSD5300 4" [101mm]. Lengths range up to 20' [6m] without the need for a splice.



Tool Rails

Tool Rail is easily installed on C-Channel or angle iron structures. The lightweight rail is offered in three sizes: TR2000 2" [51mm], HAD3000 2" [51mm], and HAD3500 2" [51mm].

HAD3000 chambered rail can be used as a fluid power distribution system for water, air, oil, and other non-caustic fluids. The non-corrosive rail serves as a manifold providing more CFM to the tool as compared to black pipe.

The TR2000 is ideal for applications under 550 lbs. [249kg] capacity. Allows festooning trolleys and plant utilities to be attached to the main line rail system.



Engineered Round Rail

RAD4700 and RAD6500 Round Rail is ideal for low friction vertical, or horizontal, linear movement. Capable of handling direct or offset loads as well as high torque applications. Designed to handle heavier loads when compared to traditional linear motion products.



Engineered Linear Rail

LRD9500 Linear Rail is ideal for floor, or side mounted, low friction horizontal movement. Capable of handling direct or offset loads. Lower maintenance alternative to hardened ground rail and bearing block. Binding is significantly reduced due to its flexible tolerances.



Jib Cranes

Jib Cranes are ideal for short transfer applications. Allows for maximum hoist height where overhead clearance is limited. Thrust bearings provide a smooth 360° rotation. Installation is quick and simple with the two-component design. Jib lengths are available up to 14ft[4.26m] and can be extended by adding a telescoping rail.

Rail Accessories



End Caps

Serves as a rail dust cover. May be used in conjunction with a mid-rail stop to form a redundant stop.

Model# MRAA4804 (left)
MRAA4011 (right) Shown



Shock Absorber

Dampens the impact of a load trolley striking the end cap.

Model# MRAA4805 Shown



Hose Management Kit

Each kit includes a filter/regulator, brackets, fittings, and pressure gauge for festooned or coiled hose.

Model# MRMS4065 Shown



End of Travel Switch

Mountable stop to prevent over travel on rail system. Trolley mounted actuator has a bypass feature.

Model# MRAA4228 Shown



Bridge Brace

Used to secure parallel rails at specific distances. Spans greater than 15ft [4.5m] require two braces.

Model# MRAA4205-8 Shown



Bridge Stop Assembly

Prevents bridges from colliding into each other.

Model# MRAA4926 Shown

(Rail Accessories Continued)



Hose Trolley

Carries festooned hose used in hose management kits.

Model# MRMA4019 Shown



Rail Brake

Pneumatic stop allows operator to park a bridge or arm on the rail. Bolts on to most Knight mainline trolleys and end trucks.

Model# MRAA4359 Shown



Cable Saddle

Adapts standard hose trolley to accommodate up to 2" [51mm] electrical cable. Velcro straps allow for an easier, quicker installation of power cables.

Model# MRMA4019 Shown



Inspection Gate

Allows for maintenance and inspection of a trolley without disassembling the system.

Model# MRAA7558 Shown



Rail Splice

Joins runways or monorails. A hanger must be used within 12" [305mm] of a splice.

Model# MRHA7503 Shown



Telescoping Rail

Extends the reach beyond the working limits of a bridge.

Model# MRES7522 Shown



Air Tractors

Provides mobility to a load or fixture. Additionally, the load or fixture can be conveyed to the next position or returned home automatically. Capacity up to 3000 lbs [1360kg]. Mini tractor has a capacity up to 200lbs [90kg].

Model# TRA4000 Shown



Transfer Switch

Allows fixtures to be transferred between work zones without cranes, fork trucks, or disassembling the system.



Load Trolleys

Trolley Options:

- Boss Trolley
- Yoke Trolley
- Eye-hook Trolley
- Balancer Trolley

Model# MRTA7006 Shown



End Trucks

Available in a variety of configurations. Selection depends on size, profile, and loading condition of runway and bridge. Dual trolleys used when loads exceed 1000lbs [453kg]; not to exceed 3000 lbs [1360kg].

Model# MRES7717 Shown

(Rail Accessories Continued)



Same Plane End Truck

Designed to elevate bridge to the same height as the runway. System stack-up heights can be reduced by as much as 11.5" [292mm].
Model# MRES4028 Shown



Rigid End Truck

Eliminates bridge skew for applications that require added stability.
Model# MRES4226 Shown



Rod and Ball Hanger

Used for direct loads such as hoists or balancers.
Model# MRHS40361 Shown



Rigid Hanger

Adjustable I-beam hangers used for kick-up loads such as arms or offset loads.
Model# MRHS40381 Shown



C-Channel Rod and Ball Hanger

Hanger with threaded rod leveling adjustments. Used for direct loads such as hoists or balancers.
Model# MRHS4034 Shown



C-Channel Bolt-On Hanger

Non-Adjustable hanger used for cantilevered or direct loads.
Model# MRHA4035 Shown

Knight Engineering Standards



Knight Industries follows Material Handling Industry Standards in determining the capacity ratings for enclosed track overhead rail systems. Each component (e.g. rail, hangers, trolleys, etc.) is individually tested to establish its ultimate failure point. From this number, a safe working load (based on a 5:1 safety factor) is assigned to the component. Each rail span length is tested to determine the maximum single point load required to achieve a predetermined deflection based on a 1:350 ratio (1" of deflection for each 350" of length). The recommended rated capacity chart is based upon single point loading for the listed spans. The maximum of 3000 lbs. [1360kg] is a function of the 5:1 safety factor for the component with the lowest tested failure point.

Balancers

Knight Balancers provide the means to balance, position, and ergonomically transfer loads via a unique "float mode" status. Positioning of a load is possible with or without using an Up/Down pendant control. Designed to be used with the entire Knight product line as well as a variety of other manufacturers' products. All balancer capacities are rated at 100 psi.

Cable Balancers



Balancers come equipped with a safety retract control mechanism. Cable Balancers have a balancing capacity up to 700 lbs. [318kg] and maximum travel distance up to 110" [279cm].
Model# KBA350-073 Shown

Chain Balancers



Designed for applications that are subject to excessive amounts of yarding, twisting, or bouncing. Chain balancers have a balancing capacity up to 700 lbs. [318kg] and maximum travel distance up to 80" [203cm].
Model# KBC350-067 Shown

Reeved Balancer



Balance capacity can be doubled by reeving. Reeved Balancers have a balancing capacity up to 1400 lbs. [635kg] and maximum travel distance of up to 55" [138cm].
Model# RKBA700-036 Shown

Dual Drum Balancer

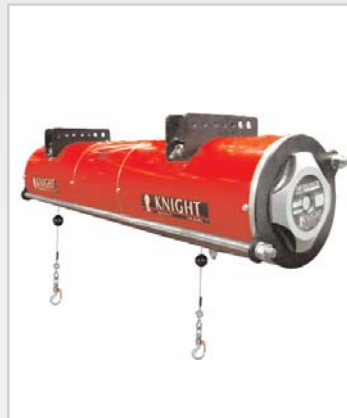

Two synchronized spools inside one housing offers added balance/control to unwieldy or lengthy loads.
Balancing from two suspension points, Dual Drum Balancers have a balancing capacity up to 700 lbs. [318kg] and maximum travel distance up to 110" [279cm].
Model# DKBA350-073 Shown

Tandem Balancer









Doubles the load capacity of a single balancer without sacrificing vertical travel. Tandem Balancers have a balancing capacity up to 1400 lbs. [635kg] and maximum travel distance up to 110" [279cm].
Model# TKBA700-073 Shown

Tandem Reeved Balancer



Handles loads up to four times heavier than the largest single cable or chain balancer. Tandem Reeved Balancers have a balance capacity up to 2800 lbs. [1270kg] and maximum travel distance of up to 55" [138cm].
Model# TRKBA700-036 Shown

Pneumatic Balancer Controls

Up/Down Pendant	Tandem Units Up/Down Pendant	High Relieving Single Balance
 <p>Variable speed control for loading and unloading varying weights. The most commonly used control for balancers. Available in straight or coiled hose and standard lengths of 10ft [3m]. Model# BCS3017 Shown</p>	 <p>Variable speed control used on Tandem Balancers for loading and unloading varying weights. Available in straight or coiled hose and standard lengths of 10ft [3m]. Model# BCS3230 Shown</p>	 <p>Supports a constant weight at zero gravity. Used for near capacity or applications greater than 150 lbs. [68 kg]. Available in straight or coiled hose and standard lengths of 10ft [3m]. Model# BCS2090 Shown</p>
Feather Touch Balance	Single Balance	Dual Balance
 <p>Typically used for light weight applications. Control is activated by an up/down movement of the control handle. Available in straight or coiled hose and standard lengths of 10ft [3m]. Model# BCS2214 Shown</p>	 <p>Supports a constant weight at zero gravity. Recommended for applications less than 150 lbs. [68kg]. Model# BCS2018 Shown</p>	 <p>Supports two different weights at zero gravity. Used in applications where the part weight does not change. Available in straight or coiled hose and standard lengths of 10ft [3m]. Model# BCS2215 Shown</p>

Balancer Accessories

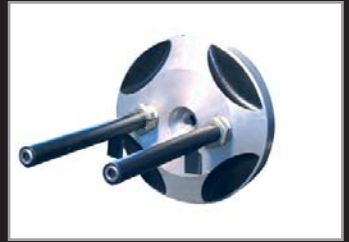

Balancer Limit Switch

Ability to set upper and lower limits. Eliminates unnecessary movements.

Model# BPA2224 Shown



External Retract Control

Hydraulic shocks provide continuous resistance to spool travel. Prevents spool from accelerating if a load is lost.

Model# BPA2089 Shown



Load Trolley

Attaches balancers to various types of rail systems or I-beams.

Model# MRTA7705 Shown



Top Mount Single Hook

Attaches a balancer by use of an eye-hook.

Model# BPA2016 Shown

Ergo Assists

Knight Ergo Assists accurately and effortlessly transfer materials of varying weights, shapes, and sizes. Combined with end-of-arm tooling, an operator can perform a variety of material handling applications. Assists are built to customer specifications.



Articulating Arms

Standard Articulating Arms are available in various sizes. Light duty are typically used for suspending single or multiple spindle torque tools. Medium duty are low profile for limited space, overhead applications. Heavy duty are ideal for bulkier loads.

Arms are either pedestal mounted or suspended from a rail system.

Maximum weight capacity up to 500 lbs. [226kg]. Maximum reach up to 96" [244cm]. Maximum travel distance up to 60" [152cm].

Model# AAA6000 Shown

Extension Arms

Enables operator to extend beyond the working limits of a rail system. A Knight Balancer or Servo Hoist mounts to the arm which lifts / lowers the load.

Extension arms are available in either Single or Dual bridge configurations. Maximum weight capacity up to 700 lbs.[317kg]. Maximum reach adjustable up to 60"[152cm]. Maximum travel distance up to 110"[275cm].

Model# JDA300073 Shown

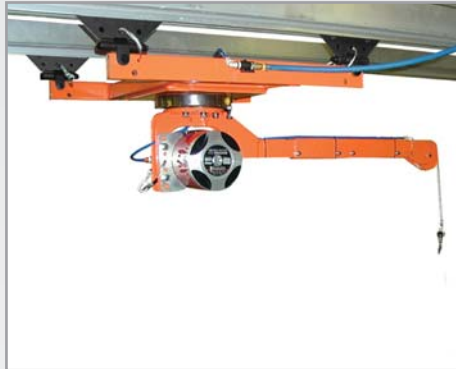

Path Guided Arms

Guides fixture through a predefined path. Ideal when part alignment is crucial. Clutch assembly option locks rotation on arm while not in use, or as required during operation.



Carriage Arms

Places the body of the arm between the runway saving up to 36" [91cm] of head room. Ideal for offset loads up to 400 lbs. [181kg] in parallel with the running rails.

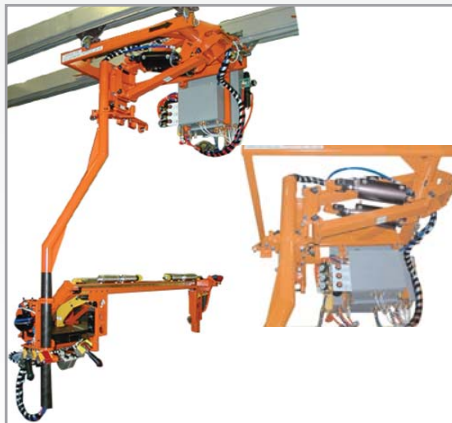

LEAN TOOLS



Seat Scoop (LTSS001)



Vacuum Cup (LTVC004)



J-Hook (LTJH001)



Magnetic (LTMG002)



Box Clamp (LTSC001)



Prong Clamp (LTSC002)

Knight Industries new family of Lean Tools are designed to be uncomplicated, durable, cost-effective Ergo Assists. Each pre-designed tool includes a balancer and pendant control. The Lean Tool Line is essentially a "pre-engineered Ergo Assist in a box."



Vertical Mast Arms

Allows for end tooling to be mounted to a rigid vertical beam. Vertical travel is achieved with a Knight Balancer, Servo Hoist, air / hydraulic cylinder, or chain hoist.

Maximum lift capacity / travel distance is based upon the lift device.

Model# VBA2000 Shown



Torque Arms

Designed to absorb torque reaction from fastening devices and balance the tool. Arm includes a standard fixed tool holder. Standard travel distance is 19"[48cm].

Custom travel distances, heights, and tool holders are available. Arms can torque up to 442ft./lbs[600Nm].

Model# ATA2500 Shown

360° Rotating Clamp Style

Adjustable Clamp Style



The 360° clamp is available in diameter sizes up to 2.5" [6.35cm]. Adjustable clamp allows user to resize tool holder to accommodate a wide variety of tools. Adjustable for vertical or horizontal tool orientations.



Side Mounted Arm

Pivot mounted arm is optimal for small tools and includes a standard tool holder. Balance capacity up to 150 lbs. [68kg]. Maximum reach up to 6'[1.8m]. Maximum travel distance up to 32"[81cm].

(Shown in use with a LRD9500 Rail System)

Model# AAA3000 Shown

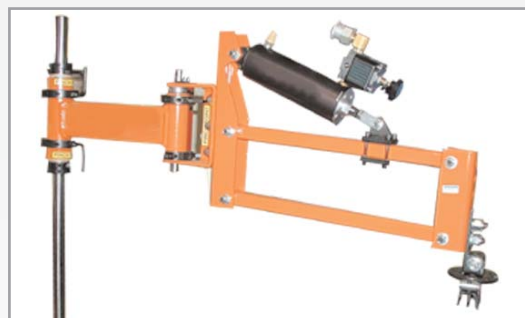

Tool Bench Arm

Ideal for small part assembly applications and includes a standard tool holder. Balance capacity up to 25 lbs.[11kg]. Absorbs torque reaction from fastening devices and balances the tool. Maximum travel distance is 13"[33cm].

Model# ABA2000 Shown



Single Cup Vacuum

Single cup vacuum fixture suspended by a Knight Servo Hoist. Transfers the torque converter to the transmission.



Multiple Vacuum Cup

Four (4) cup vacuum end effector with 90° rotate. Transfers hood from rack to weld fixture.



I.D. Clamp Style

I.D. Clamp style fixture with adjustable centers. Transfers the wheels from dunnage to conveyor.



J-Hook

Dual J-hook fixture suspended by a Knight balancer. Transfers axle from dunnage to conveyor.



Clamp Style

Clamp style fixture suspended from a Knight Articulating Arm. Loads HVAC system to the vehicle.



Clamp Style

Clamp style fixture with 90° rotate transfers the transmission to assembly station.



Clamp Style

Transfers battery from pallet to vehicle on the assembly line.



Clamp Style

Clamp style fixture suspended by an overhead extension arm. Loads front end module to the vehicle.

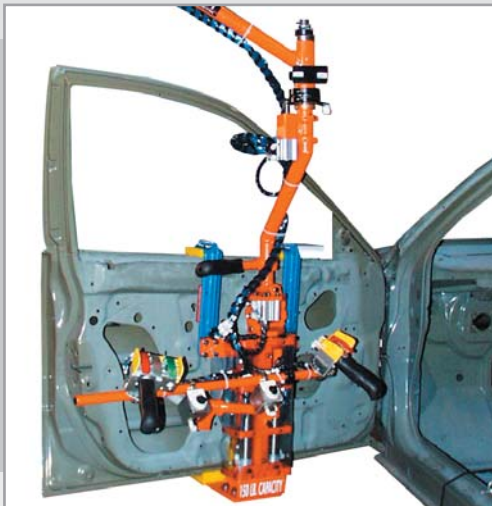

Clamp Style

Clamp style fixture removes the door from the vehicle.



Clamp Style

Clamp style fixture loads instrument panel inside the vehicle.



Clamp Style

Clamp style fixture with 45° rotate. Transfers seat to the assembly station.



Core Style

Knight Vertical Arm core style gripper with power push-off. Transfers rolls of plastic film.

Controls

Knight offers three types of control handles: pneumatic, electric, or pneumatic/electric combinations. Horizontal and vertical adjustments allows operator to maneuver handle to a comfortable ergonomic position. Control Handle Levers are marked according to customer specifications. Hose fittings and/or cables are supplied at customer request.

Pneumatic Control Handles



One (1) Button
Model# BPA9400 Shown



Two (2) Button
Model# BPA9100 Shown



Three (3) Button
Model# BPA9430 Shown



Four (4) Button
Model# BPA9310 Shown

Electrical Control Handles



One (1) Button
Model# EPA9201 Shown



Two (2) Button
Model# EPA9202 Shown



Three (3) Button
Model# EPA9203 Shown



Four (4) Button
Model# EPA9205 Shown

Lever Options



CUSTOMIZING LEVERS

Levers can be customized for identification and ease of use. Callouts are stamped and available in different languages.

PAINT COLORS

Up (Green) and Down (Red) levers are standard colors. Custom colors can be applied according to customer specification.

ANGLED and REAR TRIGGER LEVERS

Control handle levers can be angled or mounted on the back of the handle for optimum ergonomics.



Tables, Carts and Shuttles

Knight Tables raise, lift, tilt, slide, and rotate to proper ergonomic heights. Available load sensors maintain working height, reduce fatigue, and increase productivity. Standard tables have a lifting capacity up to 8000lbs[3629kg], typical platform sizes up to 62"[157.5cm] x 96"[243cm], and collapsible heights down to 4"[10cm]. Custom tables can be designed and built per customer specifications.



Lift

Lift Table raises loads to the proper ergonomic height for the operator. Lifting capacity up to 8,000 lbs.[3629kg].
Model# L3636-2000 Shown



Lift and Rotate

Rotate Table provides up to 360° rotation. Lifting capacity up to 8,000 lbs.[3629kg].
Model# LR4860C-2000 Shown



Low Profile Lift

A collapsed height as low as 4"[10cm]. Lifting capacity up to 6,000 lbs.[2722kg].
Model# LPL4353-6000 Shown



Low Profile Lift and Rotate

A collapsed height as low as 7.5" [19cm]. with the ability to rotate loads. Lifting capacity up to 6,000 lbs.[2722kg].
Model# LPLR4353-6000 Shown



Lift and Tilt

Combines lift and tilt functions. Lifting capacity up to 6,000 lbs.[2722kg].
Model# LT4860-4000 Shown



Double Scissor Lift

When extra lift is needed to raise loads to a safe ergonomic height. Lifting capacity up to 2,000 lbs.[907kg].
Model# DSL4860-1000 Shown



Turntables

One, two, or four position configurations. Parts can be continuously supplied to an assembly station. Capacity up to 8,000 lbs.[3629kg].
Model# Customized per order



Push / Tugger Cart

Fork-free carts in either push or tugger configurations. Capacity up to 1500 lbs.[680kg].
Model# Customized per order

Tables, Carts and Shuttles



Tilt

By tilting container forward, the table positions dunnage for easy loading or unloading. Lifting capacity up to 8,000 lbs.[3629kg].
Model# T4860-4000 Shown



Slide - Tilt

Maintains clearance on the operator side of the table. Lifting capacity up to 8,000 lbs. [3629kg].
Model# ST5560-4000 Shown



Corner Tilt

Tilts and positions pallet or basket to operator working level. Lifting capacity up to 4,000 lbs. [1814kg].
Model# CT3636-4000 Shown



Cart Lift

Table lifts a cart to operator working level. Lifting capacity up to 2,000 lbs.[907kg].
Model# Customized per order



Hydraulic Cart Lift

Small footprint, fork-free lift raises cart to operator working level. Lifting capacity up to 2,000 lbs.[907kg]. Available in front or side load configurations.
Model# Customized per order



Operator Platform Lift

Ergonomically positions the operator. Lifting capacity up to 2,000 lbs.[907kg].
Model# Customized per order



Smart Cart

The Smart Cart is ideal when portable powered manipulation is required for an application. Lifting capacity up to 400 lbs.[181kg].
Model# SCS435266 Shown



Smart Cart

Smart Cart with rollerbed end effector. Provides effortless loading / unloading of cumbersome materials. Lifting capacity up to 400 lbs.[181kg].
Model# Customized per order



Small Footprint Zero Loader

Convenience of ground level loading with the footprint of a standard lift table. Lifting capacity up to 4,000 lbs.[1814kg].
Model# Customized per order



Zero Loader

Ground level loading with a pallet jack when fork truck access is limited. Lifting capacity up to 4,000 lbs.[1814kg].
Model# TZ4860-2000 Shown

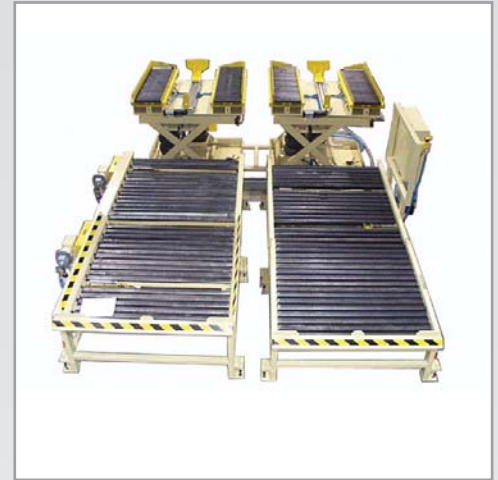

Shuttle Systems

Knight offers the highest operational efficiency in custom shuttles. Shuttle capacity up to 4,000 lbs.[1814kg].
Model# Customized per order



Powered Accumulators

Transfers parts between two workstations and offers an accumulation of parts at the off-load end. Loading capacity up to 50lbs/ft.
Model# Customized per order



Non-Powered Accumulators

Transfer parts between workstations for assembly applications. No power source required. Overhead or floor support stand.
Model# Customized per order



Small Footprint Over/Under

Exclusive design provides a shuttle system in a compact footprint. Lifting capacity up to 2,000 lbs.[907kg].
Model# Customized per order

Table Accessories



Table Controls

Controls are available in either pedestal or foot controls.



Bellows Skirting

Protective covering serves as a barrier for the operator. Keeps debris from entering the table.
Model# BSS100T Shown



Motion Stabilizer

Stabilizes loads traveling upward / downward in a smooth, consistent manner. Typically used for loads greater than 4000 lbs.[1814kg]
Model# MSD-100 Shown



Steel Riser

All steel reinforced construction ensures a safe, sturdy mounting base. Standard or custom built.
Model# ASTR-100 Shown

The Knight Website



Visit our website @ www.knight-ind.com to obtain detailed information on product lines, videos, technical manuals, brochures, and contact lists .

Knight Industries is known worldwide for:

- ▶ **Experience:** Designing and building specialty equipment since 1984.
- ▶ **Building Space:** Over 150,000 square feet
- ▶ **Distribution:** 60 Distributors Worldwide
- ▶ **Design:** State-of-the-Art 2D and 3D design software.
- ▶ **Quality Assurance:** Includes duty cycle and destructive testing capabilities.
- ▶ **Service:** Stand alone department, fully trained field service technicians.
- ▶ **Controls:** Electrical and pneumatic capabilities.
- ▶ **Build:** Full CNC , Laser/Plasma Cutting and Laser Welding technologies.
- ▶ **Support Staff:** Project Management, I.T. , Standards, Scheduling, and Graphics.



Knight Headquarters and Facilities in Auburn Hills, MI



09/07 Made With Pride In The USA



KNIGHT INDUSTRIES

1140 Centre Road
Auburn Hills, MI 48326 USA
Phone: (248) 377-4950
Fax: (248) 377-2135
www.knight-ind.com